

Emergency, Need Backup!

Design Document

Team Number: SD May21-43

Client: Collins Aerospace

Adviser: Dr. Andrew Bolstad

Team Members (Role):

James Curtis (Meeting Scribe)

Caroline Easley (Meeting Facilitator)

Marcelo Christhiam Gomes (Chief Engineer: Power Systems)

Michael Kuehn (Communications Director)

Benjamin Welte (Project Documentation)

Abbey Wilder (Test Engineer)

Stepan Zelanin (Chief Engineer: Communications)

Team Email: sdmay21-43@iastate.edu

Team Website: <https://sdmay21-43.sd.ece.iastate.edu>

Executive Summary

Development Standards & Practices Used

- ED-23C – Minimum Operational Performance Specification for Airborne VHF Receivers
- RTCA/DO-160G – Environmental Conditions and Test Procedures for Airborne Equipment
- MIL-STD-188-243A – Tactical Single Channel Ultra High Frequency (UHF) Radio Communications
- RTCA/DO-254 – Design Assurance Guidance for Airborne Electronic Hardware
- IEEE 802.3 – Ethernet Working Group
- Assorted Simple Networking Management Protocol (SNMP) standards:
 - RFC 3410 – Applicability Statements for the Simple Networking Management Protocol (SNMP)
 - RFC 3411 – An architecture for Describing Simple Networking Management Protocol (SNMP) Management Frameworks
 - RFC 3412 – Message Processing and Dispatching for the Simple Networking Management Protocol (SNMP)
 - RFC 3413 – Simple Networking Management Protocol (SNMP) Applications
 - RFC 3414 – User-Based Security Model (USM) for version 3 of the Simple Networking Management Protocol (SNMPv3)
 - RFC 3415 – View-based Access Control Model (VACM) for the Simple Networking Management Protocol (SNMP)
 - RFC 3417 – Transport mappings for the Simple Networking Management Protocol (SNMP)
 - RFC 3418 – Management Information Base (MIB) for the Simple Networking Management Protocol (SNMP)

Summary of Requirements

This project aims to produce the foundations of a simple emergency backup radio capable of transmitting and receiving signals from 117.975 to 137.000 MHz as well as from 225.000 to 400.000 MHz using amplitude modulation (AM). The radio will receive status and control signals over Ethernet using Simple Networking Management Protocol (SNMP). Future engineering teams will be able to use the prototype produced by this project as the foundation for a future product that will be able to pass civil certification.

Applicable Courses from Iowa State University Curriculum

- EE 201
- EE 224
- EE 230
- EE 321
- CprE 281
- CprE 288

New Skills/Knowledge acquired that was not taught in courses

- Expanded knowledge of radio transmitter and receiver architectures
- Increased understanding of digital communications, particularly via Ethernet
- Experience writing embedded software to control external circuitry
- Practice writing test PC software to interface with a microcontroller
- Ability to research and select adequate parts to implement a design
- Practical experience testing and debugging a project on the unit and system levels

Table of Contents

Table of Contents	3
List of Figures, Tables, Symbols, and Definitions	4
1 Introduction	5
1.1 Acknowledgement	5
1.2 Problem and Project Statement	5
1.3 Operational Environment	5
1.4 Requirements	6
1.5 Intended Users and Uses	8
1.6 Assumptions and Limitations	9
1.7 Expected End Product and Deliverables	10
2 Project Plan	10
2.1 Task Decomposition	10
2.2 Risks And Risk Management/Mitigation	12
2.3 Project Proposed Milestones, Metrics, and Evaluation Criteria	14
2.4 Project Timeline/Schedule	17
2.5 Project Tracking Procedures	19
2.6 Personnel Effort Requirements	19
2.7 Other Resource Requirements	21
2.8 Financial Requirements	21
3 Design	22
3.1 Previous Work And Literature	22
3.2 Design Thinking	23
3.3 Proposed Design	23
3.4 Technology Considerations	27
3.5 Design Analysis	28
3.6 Development Process	28
3.7 Design Plan	28
4 Testing	29
4.2 Interface Testing	30

4.3 Acceptance Testing	31
4.4 Results	31
5 Implementation	32
6 Closing Material	32
6.1 Conclusion	32
6.2 References	32
6.3 Appendix A: Abbreviations & Acronyms	33
6.4 <additional appendices TBD>	33

List of Figures, Tables, Symbols, and Definitions

Figure 1: Gantt Chart of Project Timeline	18
Figure 2: Transmitter Block Diagram	24
Figure 3: Receiver Block Diagram	25
Figure 4: Ethernet Control Circuit	26
Figure 5: Top-Level Block Diagram	29
Table 1: Frequency Range & Tuning Resolution	6
Table 2: Ethernet Command & Status Operations	7
Table 3: Design Assumptions	9
Table 4: Design Limitations	10
Table 5: Task Decomposition	12
Table 6: Risks & Mitigation Strategies	13
Table 7: Project Proposed Milestones, Metrics, and Evaluation Criteria	17
Table 8: Estimated Personnel Effort Requirements	21

1 Introduction

1.1 Acknowledgement

The design team would like to specially thank Dr. Andrew Bolstad for his technical expertise and practical advice, Brendan Getz for his oversight and support, and Collins Aerospace as a whole for the generous funding it provided for this project.

1.2 Problem and Project Statement

Pilots rely on an airplane radio for communication, so if it breaks, they can no longer communicate with air traffic control (ATC) or other aircraft. This causes many problems since ATC is no longer able to communicate with the aircraft to coordinate airspace deconfliction. It also means that the airplane pilots cannot communicate any ongoing problems to ATC.

To solve the myriad complications that can result from a radio malfunction, this project aims to create a backup radio for use as an alternate communication device in the event that an airplane's main radio fails. Designing a backup radio in its entirety is outside the scope of a two semester design class, so this project's goal is to design and implement a prototype capable of basic amplitude modulation (AM) signal transmission and reception as well as sending status updates and receiving commands via ethernet. This prototype will then be used by future engineering teams as the foundation for a full design capable of passing civil certification.

1.3 Operational Environment

The expected operating environment for this project's end product will be an airplane. As such, our product will need to be able to survive a wide range of extreme conditions specified by civilian and military aeronautic standards such as the DO-178, ED-23C, etc.

A civil-certified backup radio will need to be fully operational under the mandated temperature range (-40 to 71 degrees Celsius), and it should be able to survive for short periods of time under even more extreme temperatures without permanent damage (typically -55 to 85 degrees Celsius). The civil-certified version of this radio will also need to pass various other environmental benchmarks including vibration testing, electromagnetic radiation and susceptibility, dust/mold tolerance, and others.

The goal is that this project's final deliverable will be the foundation for a civil-certified radio, not necessarily a certifiable radio in and of itself. As such, this project's final

deliverables will be designed with the rugged environment of an airplane in mind, but compliance with the associated aerospace standards is not a strict necessity.

1.4 Requirements

This specification establishes performance requirements for the Receiver/Transmitter (hereby referred to as the RT) Airborne Emergency Back Up communication system.

Project Requirements:

1. The RT shall provide unencrypted voice communications.
2. The RT shall transmit and receive over the following frequency ranges:
 - 117.975 to 137.000 MHz
 - 225 to 400 MHz
3. The RT shall provide the following tuning increments over the defined frequency ranges:

Frequency Range	Tuning Resolution
117.975 to 137.000 MHz	8.33 kHz, 25 kHz
225 to 400 MHz	25 kHz

Table 1: Frequency Range & Tuning Resolution

4. The RT shall support Amplitude Modulation (AM) only.
5. The RT shall adhere to ED-23C (European Air Traffic Control) and shall be classified as a Class H2 receiver and a dual class transmitter (3 and 5)
6. The RT shall provide an Ethernet port in accordance with IEEE 802.3 (10/100 Base-T) for control and status operations.
7. The RT shall provide an Ethernet Simple Network Management Protocol (SNMP) interface for control and status operations.

Command	Options
Frequency	Tunable frequency from 117.975 to 400 MHz
Status	Options
Frequency	Report currently tuned frequency from 117.975 to 400 MHz

Tx/Rx Mode	Report currently operational mode
CBIT Results	Report current CBIT results (Optional, see Design Goals)
POST Results	Report POST results (Optional, see Design Goals)

Table 2: Ethernet Command & Status Operations

8. The RT shall provide a discrete input, Push-To-Talk (PTT) that is used to enable/disable transmit operations.
9. The RT shall not exceed 6.0 pounds in total weight
10. The RT shall not exceed 6.0 inches x 6.0 inches x 6.0 inches
11. The RT shall provide an input capable of accepting baseband analog voice signals.
12. The RT shall provide a balanced 150 ohm +/- 10% narrowband audio input interface.
13. The RT shall provide a balanced 600 ohm +/- 10% narrowband audio output interface.
14. The RT electronics piece part cost shall not exceed \$1500

In addition to its hard requirements, this project also has some optional design goals that the client desires. These design goals are not absolutely necessary to meet but should be considerations for the designers. If they can be achieved with little project impact, their inclusion is desirable. Considerations should be made to provision for them in a future stage, even if they are not fully completed as part of this project.

Optional Design Goals:

1. The RT should have a path to DO-178C compliance and should incorporate DO-178C design principles.
2. The RT should have a path to DO-254 compliance and should incorporate DO-254 design principles.
3. The RT should provide an interface to operate from a nominal +28V DC power source.
4. The RT should operate in a temperature range from -40 to +71° Celsius.
5. The RT should implement 121.5/243 MHz Guard Monitor capabilities.

(NOTE: Guard Monitor is defined as the simultaneous reception of the main tuned frequency along with either a signal on 243 MHz or 121.5 MHz, selectable by tuned frequency band).

6. The RT should incorporate a modular design allowing for future expansion of capabilities (FM, etc.)
7. The RT should incorporate Power On Self Test (POST) that will complete in no more than 10 seconds.
8. The RT should incorporate Continuous Built In Test (CBIT) which can be executed autonomously without affecting normal system operations.
9. BIT results should be stored in non-volatile memory
10. BIT results should be able to be queried via the Ethernet Command and Control interface.
11. The RT should incorporate a capability to the user to configure an IPv4 address.
12. The RT should allow for top level reprogramming/reloading of firmware and software.

1.5 Intended Users and Uses

The end use for this project's deliverables will be as a foundational design that can eventually be improved to include most or all of its optional design goals and successfully complete civil certification. As such, the anticipated end users for our product will include both engineers at Collins Aerospace and, following the design's completion and certification, airplane pilots.

The fact that this design will be passed to other project teams for further development means that modularity will be a key focus in this project's development to make the final design easily modifiable by future teams. Consequently, concise and perspicuous project documentation will also be critically important.

1.6 Assumptions and Limitations

Assumption:	Justification:
The final product will eventually be used outside the United States.	The project's client wants the design to conform to European standards (ED-23C).
The final product will not be used unless an aircraft's primary radio fails.	This is the definition of a backup radio.
The final product is not intended for use in small engine aircraft.	This project's certification standards apply primarily to commercial aircraft.
The final product will be used by one person at a time.	Aircraft instrumentation is typically designed for a single active user.

Table 3: Design Assumptions

Limitation:	Justification:
The final product must be smaller than 6" x 6" x 6".	This is one of the client's requirements.
The final product must cost less than \$1,500 per unit.	This is one of the client's requirements.
The final product must weigh less than 6 lbs.	This is one of the client's requirements.
The final product must be delivered by May 4 th , 2021.	This is a class requirement.
The final product should ideally operate off of a 28 Volt DC power supply if possible.	This is one of the client's requirements and is representative of the operational environment in an airplane.
This design's end users will not be blind, deaf, or have other sensory impairments.	The end users, airplane pilots, must possess basic levels of sight and hearing to fly an aircraft.

The environmental tests necessary for civil certification will not be performed during this project's schedule.	This project lacks the necessary facilities to verify full compliance with civil certification requirements.
---	--

Table 4: Design Limitations

1.7 Expected End Product and Deliverables

The first deliverable, a paper design, should be finished by November 25th, 2020. This design will be created in accordance with the requirements outlined in section 1.4 of this report and the limitations listed in section 1.6. The first deliverable will be sufficient to theoretically implement all project requirements and as many optional design goals as possible.

The second deliverable, a functional prototype of the radio, should be finished by May 4th, 2021. This prototype will be based on the paper design listed as the first deliverable. The second deliverable should accordingly implement all project requirements and as many of the optional design goals as deemed feasible by the design team.

The third and final deliverable is a completed design document that will include all of the relevant technical information and design specifications pertaining to this project. It will also include results from testing the second deliverable, the radio prototype. This third deliverable is also due May 4th, 2021.

The end product for this project is due May 4th, 2021 and is a combination of the second and third deliverables. As such, it will include an assembled radio prototype along with a design document detailing its specifications and testing results.

Commented [ZS1]: These tie in with the goals. What deliverables are necessary to meet the goals outlined in the introduction?

2 Project Plan

2.1 Task Decomposition

The task breakdown for this project is given in the following table:

Task No.	Description	Dependent On:
1	Initial Research <ul style="list-style-type: none"> • Subtask 1: Define the problem • Subtask 2: Determine project requirements • Subtask 3: Define each task and subtask 	This is the first task and does not depend on other tasks.

2	<p>Transmitter Design</p> <ul style="list-style-type: none"> • Subtask 1: Research transmitter architecture • Subtask 2: Design an oscillator that will generate a carrier wave at the desired frequency. • Subtask 3: Design an amplitude modulator that will transmit a message through the carrier wave. • Subtask 4: Design a tuner that will be used to choose which frequency the user wants to transmit at. • Subtask 5: Combine each component and simulate the final transmitter design 	<p>This task is dependent on task 1, the initial research of the overall design and the project requirements.</p> <p>Each subtask will depend its predecessor.</p>
3	<p>Receiver Design</p> <ul style="list-style-type: none"> • Subtask 1: Research receiver architecture. • Subtask 2: Design a modulated signal amplifier that will amplify the transmitted signal from the antenna. • Subtask 3: Design a demodulator that will be used to recover the message from the modulated signal. • Subtask 4: Design an audio amplifier that will amplify that final demodulated message so it can be heard. • Subtask 5: Design a guard monitor that will allow the user to tune into two separate channels. • Subtask 6: Combine each component and simulate the final receiver design. 	<p>This task is dependent on task 1, the initial project research.</p> <p>Each subtask will depend on its predecessor.</p>
4	<p>An ethernet Simple Network Management Protocol (SNMP) interface is needed for control and status operations.</p> <ul style="list-style-type: none"> • Subtask 1: Research ethernet hardware architectures and SNMP. • Subtask 2: Write test PC software that allows the user to send commands • Subtask 3: Design a circuit to implement SNMP control. 	<p>This task will rely on task 1, the initial project research.</p> <p>Subtasks 2-4 depend on subtask 1.</p> <p>Subtasks 5-7 are</p>

	<ul style="list-style-type: none"> • Subtask 4: Write software for the control circuit's microcontroller. • Subtask 5: Implement POST (Power On Self Test). • Subtask 6: Implement CBIT (Continuous Built-in Self Test). • Subtask 7: Implement configurable IPv4 address. • Subtask 8: Integrate each unit and test. 	<p>extensions of subtask 4.</p> <p>Subtask 8 depends on subtasks 1-7.</p>
5	<p>Integrate the final design's components together</p> <ul style="list-style-type: none"> • Subtask 1: Perform unit testing to verify each component's individual operation. • Subtask 2: Integrate the components together. • Subtask 3: Test the integrated design. • Subtask 4: Diagnose problems and make design changes if necessary. 	<p>This task is dependent on the completion of tasks 1-4.</p> <p>Each subtask depends on its predecessor.</p>
6	<p>Prototype Implementation</p> <ul style="list-style-type: none"> • Subtask 1: Select and purchase necessary parts. • Subtask 2: Build the prototype • Subtask 3: Test the prototype 	<p>This task depends on the completion of task 5.</p>

Table 5: Task Decomposition

2.2 Risks And Risk Management/Mitigation

The following table identifies risks associated with each project steps and identifies a mitigation plan if the probability of a risk's occurrence is 0.5 or higher.

Task	Risk(s)	Probability	Mitigation Plan
<i>Initial Research</i>	Critical information may not be found.	0.1	
<i>Transmitter Design</i>	Initial design ideas may prove unworkable	0.5	Multiple transmitter architectures will be researched, and

			alternate designs will be developed as alternatives.
<i>Receiver Design</i>	Initial design may prove unworkable.	0.5	Multiple receiver architectures will be researched, and alternate designs will be developed.
<i>SNMP control</i>	Different ethernet hardware may need to be selected.	0.5	Several different methods for receiving and sending ethernet will receive design attention.
	Chosen test software may not interface with the unit well.	0.5	Alternative programs will be considered while planning the test environment.
<i>Component Integration</i>	Components may prove incompatible.	0.5	See risk mitigation strategies for individual unit redesigns.
<i>Power (Optional)</i>	The design team may have insufficient time to develop power circuitry.	0.75	Implementing circuitry to power the entire radio from a 28V DC supply is a stretch goal, not a design requirement, and is therefore not critical to include.
<i>Prototype Construction</i>	Chosen parts may prove incompatible.	0.2	

Table 6: Risks & Mitigation Strategies

2.3 Project Proposed Milestones, Metrics, and Evaluation Criteria

Tasks (and Subtasks):

Completion Criteria:

Initial Research	
Create a problem definition	Client approval
Determine project requirements	Client verification
Determine tasks and subtasks	Completion of the design document's 2 nd chapter.
Transmitter Design	
Research transmitter architectures	Engineers have sufficient knowledge to begin transmitter design.
Design a local oscillator	Selection of local oscillator design and accompanying implementation with CAD software.
Design an AM modulator	Selection of AM modulator design and accompanying implementation with CAD software.
Design a tuner	Selection of tuner design and accompanying implementation with CAD software.
Integration and simulation	Completion of full transmitter schematic accompanied by simulations verifying that it can transmit high-frequency AM carrier waves.

Receiver Design

Research receiver architectures

Accrual of sufficient knowledge to begin transmitter design.

Design a low-noise signal amplifier

Selection of low-noise signal amplifier design and accompanying implementation in CAD software.

Design an AM demodulator

Selection of AM demodulator design and accompanying implementation in CAD software.

Design a demodulated signal amplifier

Selection of message signal amplifier design and accompanying implementation in CAD software.

Design a guard monitor

Selection of guard monitor design and accompanying implementation in CAD software.

Integration and simulation

Completion of full receiver schematic accompanied by simulations verifying that it can receive and demodulate a high-frequency AM signal and convert it into a low-frequency audio signal.

SNMP Control/Status Design

Research SNMP

Accrual of sufficient knowledge to begin writing test PC and microcontroller software.

Write PC test software

Completion of test software with a user interface that allows transmission of SNMP status/control messages to the radio.

SNMP system design	Selection of an appropriate microcontroller and surrounding circuitry to achieve SNMP control of the radio
Write microcontroller SNMP software	Implementation of SNMP message reception for PC-based SNMP requests that controls the radio's behavior based on each command.
Implement CBIT (Continuous Built-In Test)	Completion of software to implement CBIT functionality.
Implement POST (Power On Self Test)	Completion of software to implement POST functionality.
Implement configurable IPv4 address	Completion of software to implement configurable IPv4 functionality.
Integration and testing	Verification that the microcontroller can receive SNMP messages from a test PC and query/command the radio accordingly.
Component Integration	
Initial component design	Completion of each individual circuit component (outlined in tasks 2-4).
Device integration and simulation	Functioning combination of the transmitter, receiver, and SNMP control circuits into a single design.
System Redesign	Modification of any components that cease functioning after integration to restore correct operation.

Prototype Construction

List necessary parts

Creation of a complete list of necessary parts complete with specific part numbers, prices, and vendors.

Build the prototype

Construction of a prototype of the integrated RT system that can be powered on.

Test the prototype

Verification that testing demonstrates the final design's compliance with its requirements.

Table 7: Project Proposed Milestones, Metrics, and Evaluation Criteria

2.4 Project Timeline/Schedule

The following Gantt chart shows this project's timeline in terms of each task and subtask:

Commented [EC2]: This is the best way I could figure out how to get the gantt chart here, if someone has a better way feel free to change it

SD May 21-43

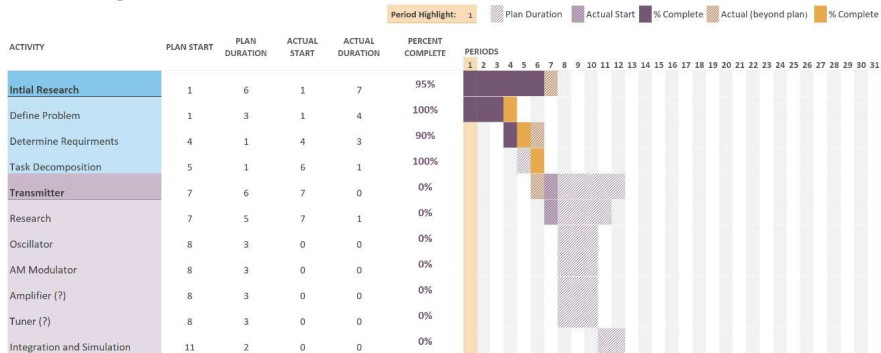

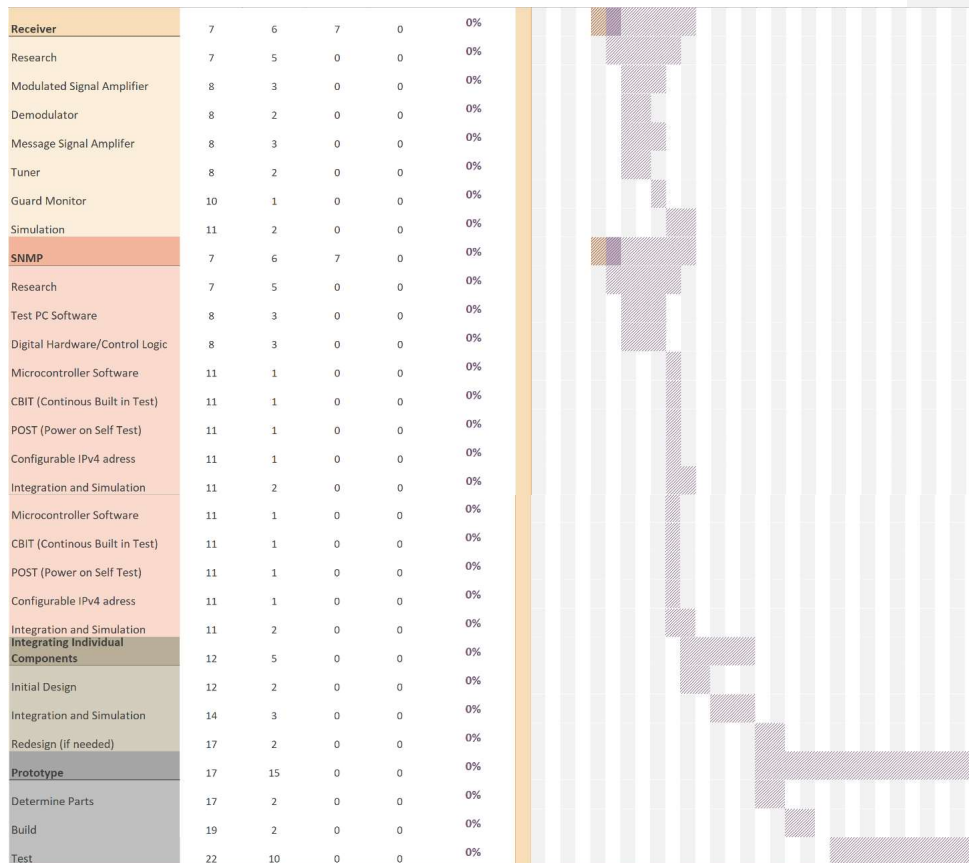

Figure 1: Gantt Chart of Project Timeline

2.5 Project Tracking Procedures

To keep track of work and communication, the design team will use Microsoft Teams. The most significant benefit of MS Teams is that it allows for the creation of collaborative Microsoft Office files that can be modified simultaneously by multiple users. It also allows the design team to track its schedule using built-in features, create separate discussion channels for different topics, and engage in virtual meetings. This amalgamation of critical functions in a single software application will help the design team to make quick, efficient progress.

2.6 Personnel Effort Requirements

The following table displays the estimated time needed for the design team to complete each of its tasks and subtasks:

Task or Subtasks	Estimated Number of Person Hours Required to Complete
Initial Research	
Initial Research: Define Problem	80
Initial Research: Determine Requirements	10
Initial Research: Task Decomposition	10
Initial Research: Total Estimated Time	100
Transmitter	
Transmitter: Research	60
Transmitter: Local Oscillator	40
Transmitter: AM Modulator	40
Transmitter: Amplifier	30
Transmitter: Tuner	25
Transmitter: Integration and Simulation	40

Transmitter: Total Estimated Time	235
Receiver	
Receiver: Research	60
Receiver: Modulated Signal Amplifier	30
Receiver: Demodulator	30
Receiver: Message Signal Amplifier	20
Receiver: Tuner	25
Receiver: Guard Monitor	20
Receiver: Simulation	30
Receiver: Total Estimated Time	215
SNMP	
SNMP: Research	60
SNMP: Test PC Software	40
SNMP: Digital Hardware/Control Logic	60
SNMP: Microcontroller Software	40
SNMP: CBIT (Continuous Built in Test)	30
SNMP: POST (Power on Self-Test)	30
SNMP: Configurable IPv4 address	30
SNMP: Integration and Simulation	20
SNMP: Total Estimated Time	310
Component Integration	

Component Integration: Initial Design	60
Component Integration: Testing	60
Component Integration: Redesign - Optional	0 - 150
Component Integration: Total Estimated Time	120- 270
Prototype	
Prototype: Determine Parts	40
Prototype: Build	40
Prototype: Test	40
Prototype: Total Estimated Time	120

Table 8: Estimated Personnel Effort Requirements

2.7 Other Resource Requirements

The design team will need access to DO-178C, DO-254, ED-23C documents to meet civil certified and European Air Traffic Control requirements. In terms of parts, the designers will need access to basic circuit components such as resistors, capacitors, inductors, diodes, and operational amplifiers in addition to a microcontroller (or possibly an FPGA board) for the SNMP control logic. Standard lab equipment such as variable power supplies, oscilloscopes, voltmeters, and ammeters will be needed to test the final prototype.

2.8 Financial Requirements

Currently the design team is allotted \$1,500.00 in funding to meet its goals. The entirety of the project must comply with this budget.

3 Design

3.1 Previous Work And Literature

The design team conducted market research prior to starting the design process. They discovered that a company called Leonardo produces a commercial solution similar to this project: the SRT-700 family of V/UHF airborne transceivers [2]. Every unit in this product family shares the following key features:

- 30 MHz – 512 MHz frequency range
- FM & AM support
- ED23-B compliancy
- Control over the MIL-STD-1553B bus, ARINC 429 Bus, or RS-485 Serial Line

According to the information available from Leonardo, their product differs from this project in several key areas. The following list encompasses this project's requirements that Leonardo's radio does not meet:

- 117 MHz - 200 MHz & 250 MHz – 400 MHz frequency ranges
- AM modulation only
- Pathway to ED-23C compliancy
- Ethernet status/control using the SNMP protocol

Rhode and Schwartz also produces a similar product, the R&S®Series5200 radios [1]. The main features of these radios include:

- 112 MHz – 156 MHz and 225 MHz – 400 MHz frequency ranges
- Redundant AC / DC power with automatic switchover
- Double Side Band (DSB) AM in line with EN 300676 (VHF) and EN 302617 (UHF)

However, Rhode and Schwartz has not made a detailed description of this product line publicly available. It is unclear whether it is an air to ground radio designed for airplanes or just for ground to air communications.

After assessing products currently on the market, the design team decided not to strictly follow any previous work since none of the commercially available radios provide a clear path to meeting this project's requirements. The product produced by this project will operate on different frequency ranges and will comply with different commercial standards than any commercially available airborne radios.

3.2 Design Thinking

During the “empathize” phase of design thinking, the design team acquired knowledge regarding similar products already on the market, and as a result, it became clear that potential users for an airborne backup radio need a product capable of transmitting AM signals from 117 MHz to 200 MHz & 250 MHz to 400 MHz while complying with the ED-23C European commercial standards, among others.

During the "define" stage, the design team did more in-depth research on AM radio designs and civil and military standards. The team discovered that several different radio architectures could fulfill this project’s requirements and that these designs could be realized using a wide variety of parts.

To improve the design process during the "ideate" phase, the design team split into three sub-groups to design the transmitter, receiver, and SNMP control circuitry. Each sub-team produced design ideas using the knowledge acquired during the “define” stage. These preliminary design ideas included several pairs of alternative ideas that both offered valid paths to a design solution; for example:

- Creating a single integrated circuit to modulate the transmitted signal using a local oscillator and a mixer as opposed to creating separate ICs for the mixer and oscillator.
- Using a bandpass filter that can be tuned to cover both frequency bands vs. using an analog multiplexor to choose between separate bandpass filters for both bands.
- Designing a receiver using the direct conversion or the superheterodyne method.
- Selecting an Arduino, the TI Launchpad, or a Raspberry Pi, for the project’s microcontroller.
- Sharing the local oscillator between the transmitter and receiver as opposed to having independent oscillators.

3.3 Proposed Design

Because the client’s standards specify that the design must be a radio, the design team had limited options to solve the problem within the specified financial and time constraints. The team deemed direct conversion and superheterodyne receiver architectures to be the two most viable designs, meaning that either one could have realized the necessary transmission bandwidths. A microcontroller was realistically mandatory to realize SNMP control of the radio, and many other components – such as a linear oscillator - became obvious necessities for producing a working radio.

In short, most of the design decisions related to choosing specific parts to realize an architecture capable of satisfying the project's requirements. Currently, the design team is in the process of selecting parts in order to realize a theoretical design which includes a transmitter, receiver, and SNMP control circuit. Detailed descriptions of each entity are presented below.

Transmitter:

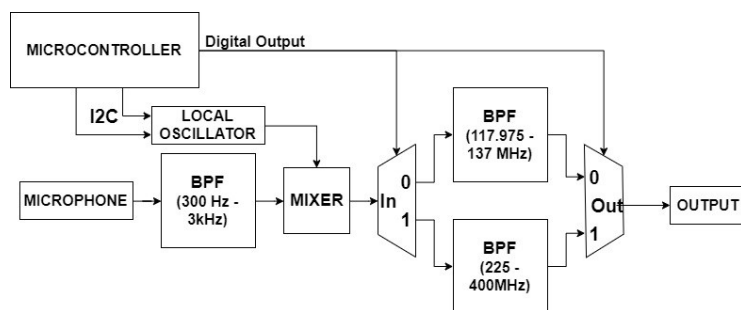

Figure 2: Transmitter Block Diagram

Commented [GC3]: I am not sure if this description is clear enough, so please feel free to make any changes. Thanks!

The initial plan for the transmitter includes a microphone, a few band-pass filters (BPF), a local oscillator (LO), a mixer, an analog multiplexer, and an analog demultiplexer.

First, the microphone captures the external sound whenever the push to talk button is pressed, and this signal is then filtered by a 300Hz to 3kHz BPF. This first BPF is used to filter the human voice since it is the essential sound that needs to be transmitted.

The resulting filtered signal is then modulated using two components, a LO and a mixer IC. The LO receives a command via I2C from the microcontroller to adjust its output signal to the desired frequency. Then, it is mixed with the audio signal coming from the BPF. This process modulates the amplitude of the LO signal containing the audio information.

To transmit the signal obtained from the previous step, its frequency must fall within the desired band. A 1:2 analog multiplexer, one 117.975MHz to 137MHz BPF, one 225MHz to 400MHz BPF, and a 2:1 analog demultiplexer will be used to ensure that this is the case. The multiplexer and the demultiplexer receive a signal from a discrete Push-to-Talk input (PTT) to select which BPF the signal must pass through. The mixer's output connects to the input of the demultiplexer, whose outputs connect to each BPF. Similarly, the output of each BPF connects to each input of the multiplexer, and the multiplexer's output is the signal the radio will transmit.

This transmitter design fulfills the requirements to (1) provide unencrypted voice communications, (2) transmit signals over the specified frequency range, (3) transmit signals on the specified frequency channels, (4) support only AM modulation, (11) provide an input capable of accepting baseband analog voice signals, and (12) provide a balanced 150 ohm +/- 10% narrowband audio input interface.

Receiver:

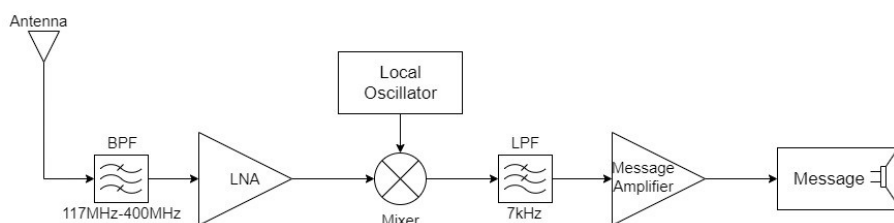

Figure 3: Receiver Block Diagram

The receiver will send an input signal through a series of filters and amplifiers to produce an audible message.

First, the receiver will get an input from an antenna that will be modeled during testing with a cabled connection. This initial input will then pass through a BPF to eliminate signals outside the audible frequency range before going through a low-noise amplifier (LNA). The LNA is necessary to combat the inevitable attenuation of the message signal during transmission.

After being amplified, the signal will be frequency-shifted by a local oscillator and then filtered again, this time by a low-pass filter (LPF). The oscillator shifts the amplified signal so that it is centered around a frequency of zero as opposed to its original center, the frequency that it was broadcasted on. The LPF then ensures that the final signal is restricted to the bandwidth of the channel that the receiver is tuned to.

Finally, the message signal will be amplified again before being sent to a speaker or a similar device to be broadcast.

This transmitter design fulfills the requirements to (1) provide unencrypted voice communications, (2) receive over the specified frequency range, (3) receive on the specified frequency bandwidths, (4) support amplitude modulation only, and (13) provide a balanced 600 ohm +/- 10% audio output interface.

SNMP Control

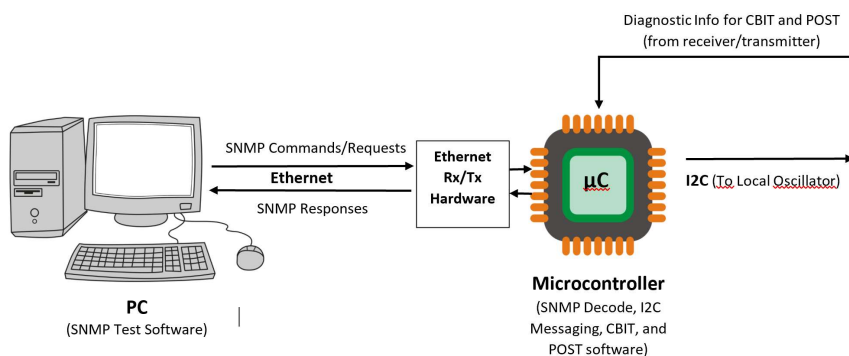

Figure 4: Ethernet Control Circuit

The SNMP control circuit will receive SNMP commands and requests from test software running on a computer. Ethernet hardware will enable a microcontroller to decode the SNMP messages before accordingly sending control signals to the rest of the radio.

The test software will be written in Python and will have the ability to send simple SNMP commands and requests to the microcontroller to change and query the radio's operating frequency. The SNMP messages will be sent over a physical ethernet cable.

Ethernet hardware will then receive the SNMP messages from the test software before sending the messages to a microcontroller. The microcontroller will then decode the SNMP message and perform the appropriate action such as setting the oscillator frequency with an I2C command or reporting back the frequency channel currently being transmitted or received on.

This SNMP control circuit fulfills the design requirements to (6) provide a standard ethernet port and (7) provide an SNMP interface capable of supporting the specified commands while also fulfilling optional design goals to implement POST and CBIT.

Additional design requirements such as (9) the radio shall not exceed 6.0 pounds in total weight and (10) the radio's size shall not exceed 6.0 inches by 6.0 inches by 6.0 inches will be observed during part selection. Conforming to ED-23C European commercial standards (requirement (5)), need not be met during this iteration of the project, but future versions will need to pass ED-23C certification, so the ED-23C standards will be used as guidelines throughout the design process.

3.4 Technology Considerations

Several alternative design approaches, technologies and solutions were considered and rejected during the project's design stage. The following overview summarizes the decisions made:

1. Using a superhetrodyne receiver architecture as opposed to direct conversion.
 - a. The key weakness of this approach is the potential for DC leakage from the LO circuit into the demodulated signal.
 - b. The main strength of this approach is its simplicity: the signal path is shorter (fewer filters are required and no dedicated demodulator circuit is used) which leads to a lower potential for signal degradation, less components used, and a lower overall cost. Because of these numerous benefits, the design team elected to implement a direct conversion architecture.
2. Using a Raspberry Pi or an Arduino to implement digital control over Ethernet using the SNMP protocol.
 - a. A Raspberry Pi provides more flexibility to a programmer than an Arduino.
 - b. However, a Raspberry Pi would use significantly more power than an Arduino and also cost significantly more, making an Arduino the more ideal choice for a low-cost project such as this. The design team elected to use an Arduino.
3. Using designing every structural component in the radio as opposed to incorporating commercially available components into the design.
 - a. Commercially available components will come with specific performance metrics and features that the design team cannot control.
 - b. However, designing and testing each building block of the receiver, transmitter, and SNMP control would require extensive time. As a result, the design team chose to use commercially available components to streamline the project's implementation phase.

3.5 Design Analysis

The design team currently has not had a chance to test or simulate the proposed design; results will be forthcoming as the project progresses.

3.6 Development Process

The design team has been following the waterfall development process which is the most traditionally used project model and is heavily dependent on planning. The major drawback to the waterfall process is the difficulty of introducing major changes to a design after its implementation, but the design team felt that this will not adversely affect the project because of its rigid structure – most of the requirements are not flexible since they correspond to commercial aviation standards, so major changes seem unlikely to be needed..

3.7 Design Plan

This project's separate components – receiver, transmitter, and SNMP control – will be designed and tested in isolation before being integrated into one cohesive unit. Refer to section 3.3 for a discussion of each individual module. The majority of the project's design requirements are satisfied by individual modules; only requirements (9) and (10) which constrain the final product's weight and dimensions will be considerations while combining the units into one cohesive structure.

The aforementioned requirements will be a consideration during the final design's assembly because of the primary use case discussed in section 1.5: the product will be used on airplanes as an emergency backup radio. As such, it will need to possess physical dimensions amenable to compact storage.

The receiver and transmitter modules will depend on the SNMP control circuit to configure their local oscillators to receive on the desired frequency band, but otherwise the three primary modules will operate independently since the radio's receive and transmit functions will use entirely separate circuits. The microcontroller in the SNMP circuit may optionally collect diagnostic data from the receiver and transmitter to meet the non-mandatory goal of performing POST and CBIT, but this is not a strict dependence since POST and CBIT can simply report that the receiver and/or transmitter do not work in the event that they fail.

The following block diagram shows the interaction between the project's three primary components:

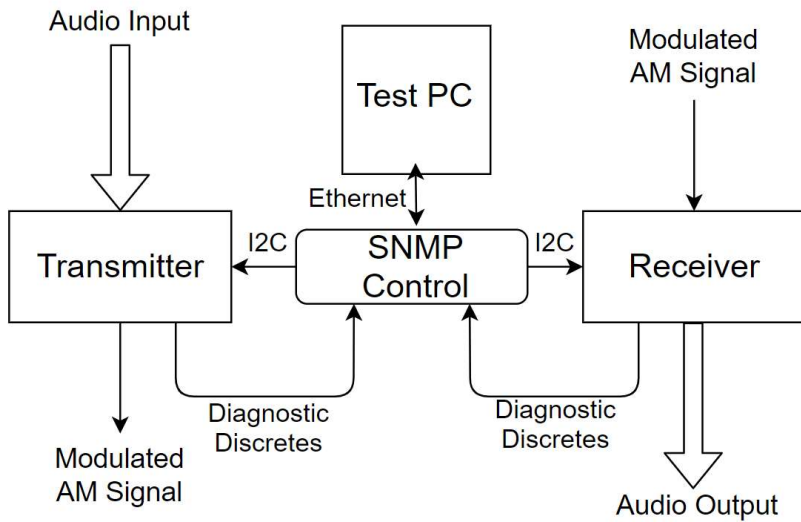

Figure 5: Top-Level Block Diagram

4 Testing

4.1 UNIT TESTING

Receiver

The receiver circuit will need to be tested to confirm that it can receive, demodulate, and output audio signals from any of the frequency channels outlined in section 1.4. Although the product will presumably use an antenna to receive an input in the environment of an airplane, due to legal restrictions, the design team will be modeling the output from an antenna using a cabled connection to the unit.

Transmitter

The transmitter circuit will need to be tested to confirm that it can broadcast an audio input on any of the output channels outlined in section 1.4. Any human voice can be used as the audio input, and an oscilloscope can be used to observe the audio output and confirm its correct modulation. Again, a cabled connection will be substituted for the antenna that will probably be used to broadcast the modulated signal in an airplane.

SNMP Control Circuit

The SNMP control circuit will need to be tested to verify that it can respond appropriately to SNMP commands specifying the radio's transmit/receive frequency as well as SNMP requests querying the radio's current status. Correct output for an SNMP command specifying an operating frequency would consist of an I2C signal from the microcontroller that correctly sets the linear oscillator to generate the desired signal. Correct output for an SNMP request querying the radio's operating status would consist of an SNMP response broadcast over ethernet that communicates the requested metrics of the radio.

PC Test Software

The test software for the computer will need to be tested to verify its correct operation prior to the team using it to send commands to the SNMP control circuit. Testing should verify that the test software can send SNMP commands over Ethernet to specify an operating frequency for the radio as well as SNMP requests that query the radio's current operating mode.

4.2 Interface Testing

Transmitter/Receiver Interface

As our system utilizes a discrete push-to-talk (PTT) button, it should interface with both the receiver and the transmitter. The receiver should always be active unless the PTT is engaged, in which case the transmitter will be active. Thus, after combining the receiver and transmitter into a single unit sharing the PTT interface, the unit will need to be tested to verify that it can be temporarily configured to transmit instead of receiving using the PTT button.

Transmitter/SNMP and Receiver/SNMP Interfaces

In addition to the PTT discrete, the radio will be controlled by SNMP commands transmitted over Ethernet. There must accordingly be interfaces between the SNMP control circuit and both the transmitter and the receiver. Two main types of SNMP structures will require testing: commands to change the current transmit/receive frequency, and requests that simply query the current frequency from the unit.

In order to test that these commands and requests achieve the desired configuration and/or fetch the desired information, an oscilloscope can be used to assess the device's current operating mode as well as the frequency being transmitted or received before comparing it to the content of an SNMP command and its response.

4.3 Acceptance Testing

Acceptance testing will include demonstrating that the radio can receive and transmit throughout the required frequency band. The team will also need to verify that a user can control the radio using SNMP commands in addition to querying its current status.

To verify transmit functionality mode, an oscilloscope can confirm that the unit outputs a correctly modulated AM signal. As the radio is tuned to different frequencies, the oscilloscope should also reflect those changes. Beyond looking at the output, frequency response testing should also be employed to verify that the output signal stays within the specified bandwidth. For this test, white noise can be supplied as an audio input to verify that all unwanted frequencies are filtered out. Power of the output signal will also be measured.

The receive side of the radio will undergo a similar test to the transmitter. An AM input signal will be varied over the required frequency band to verify that the radio is able to demodulate it into a coherent message signal.

Throughout these tests, the unit's SMNP control will also be tested since it will be used to set the radio's operating frequency and query the radio's diagnostic information. Correct SNMP operation can be confirmed by verifying that the unit is tuned to the correct frequencies and that the control circuit is accurately reporting the radio's status.

Other nonfunctional tests will be performed such as weighing and measuring the final product to confirm that it meets its required physical dimensions.

Throughout testing, Collins Aerospace will be informed of the design team's progress as well as any difficulties that emerge. The team will seek their advice regarding how best to implement certain requirements or circumvent challenges.

4.4 Results

The design team has not yet had the opportunity to test its design. Results will be forthcoming once testing has been undertaken.

5 Implementation

Describe any (preliminary) implementation plan for the next semester for your proposed design in 3.3.

6 Closing Material

6.1 Conclusion

Summarize the work you have done so far. Briefly re-iterate your goals. Then, re-iterate the best plan of action (or solution) to achieving your goals and indicate why this surpasses all other possible solutions tested.

6.2 References

List technical references and related work / market survey references. Do professional citation style (ex. IEEE).

- [1] "R&S Series 5200 Radios." Rohde & Schwartz, Munich, Germany, May-2020.
- [2] "Home," *Leonardo*. [Online]. Available: <https://www.leonardocompany.com/en/home>. [Accessed: 23-Oct-2020].

6.3 Appendix A: Abbreviations & Acronyms

Abbreviation/Acronym	Definition
ATC	Air Traffic Control
AM	Amplitude Modulation
RT	Receiver/Transmitter
SNMP	Simple Networking Management Protocol
CBIT	Continuous Built-in Test
POST	Power On Self Test
PTT	Push to Talk
IC	Integrated Circuit
LO	Local Oscillator
BPF	Bandpass Filter
DSB	Double Side Band
LNA	Low-Noise Amplifier

6.4 <additional appendices TBD>